

Thermodynamic Properties of the Enzymatic Hydrolysis of Sunflower Oil in High-Pressure Reactors

Mateja Primožič, Maja Habulin, and Željko Knez*

Faculty of Chemistry and Chemical Engineering, University of Maribor, 2000 Maribor, Slovenia

ABSTRACT: On the basis of our previous results, where optimal conditions for the lipase-catalyzed hydrolysis of sunflower oil in a high-pressure batch stirred tank reactor were determined, some thermodynamic and kinetic properties of lipase preparation Lipolase 100T (*Aspergillus niger* lipase) were established. Activation energy (32.7 kJ/mol) was determined from an Arrhenius plot. Activity of the Lipolase 100T increased between 35 and 50°C, but with further temperature increase thermal deactivation occurred. The thermal deactivation rate constant was 0.40, and the deactivation enthalpy was 123.0 kJ/mol. Because of the desirability of continuous applications of enzyme-catalyzed reactions, a high-pressure continuous flat-shape membrane reactor (HP CFSMR) was designed. Hydrolysis of sunflower oil in this reactor was performed. Maximal conversion in the HP CFSMR was achieved after 1 h. A polysulfone membrane was successfully used as a separation unit, and the highest conversion of FFA was determined at 50°C, 200 bar, and a flow rate for substrates of 0.1 mL/min (each).

Paper no. J10347 in *JAACS* 80, 785–788 (August 2003).

KEY WORDS: High-pressure, hydrolysis, lipase, membrane reactor, sunflower oil, supercritical carbon dioxide, thermodynamic properties.

Enzyme-catalyzed reactions are superior to conventional chemical methods in the context of mild reaction conditions, high catalytic efficiencies, the inherent selectivity of natural catalysts, which result in much purer products, and lower energy input. Enzymes lower the activation energy for a reaction and make it possible for substrate molecules with smaller internal energies to react (1). The most important influence on the position of equilibrium of an enzyme-catalyzed reaction and on the yield of product that can be expected is the overall free energy change of the reaction (2). On the basis of the results of our previous research involving the hydrolysis of sunflower oil in a high-pressure batch stirred tank reactor (3), it was desirable to determine some thermodynamic properties (activation energy, free energy change, Gibbs energy, enthalpy and entropy of formation and deactivation, deactivation constant) of the reaction. Activation energy can be properly determined from an Arrhenius plot; however, the temperature range is quite limited (1). In the case when tem-

peratures significantly higher than the usual biological range are considered, thermal deactivation occurs and the Arrhenius rate dependence no longer occurs (4).

Using enzymes in high-pressure batch systems may cause changes in biocatalyst activity due to the pressurization/depressurization influence. Continuous reactors employing supercritical fluids have the advantage over batch reactors in that they do not require depressurization to feed in the reactants or to recover the products (5). Therefore, a high-pressure continuous stirred tank membrane reactor, where polysulfone membrane was used as a separation unit, was constructed and is tested here. The hydrolysis of sunflower oil was performed in this membrane reactor to compare reactions in the batch and continuous modes at supercritical conditions. The influence of substrate flow rates, pressure, and temperature on the conversion was determined.

EXPERIMENTAL PROCEDURES

Enzyme, chemicals, and membrane. Lipolase 100T, a nonimmobilized, dried preparation of *Aspergillus niger* lipase, was kindly donated by Novo Nordisk A/S (Bagsvaerd, Denmark).

Sunflower oil was purchased from Oljarica Oil Factory (Kranj, Slovenia). (The amount of linoleic acid was 64.6% and the amount of oleic acid was 21.1%; determined by GC.) Potassium phosphate buffer (0.1 M; pH = 7) and all other chemicals were from Merck (Darmstadt, Germany).

Carbon dioxide (99.95% volume pure) was supplied by Messer MG (Ruše, Slovenia).

Polysulfone flat-shaped membrane (10,000 M.W. cutoff) was supplied by Sartorius (Goettingen, Germany).

Each data point represents the average of at least two measurements (or the average of three measurements, when problems with operation at high pressure appeared).

Hydrolysis in high-pressure continuous flat-shaped membrane reactor (HP CFSMR). The continuous high-pressure enzyme membrane reactor is shown in Figure 1. The polysulfone membrane was placed between two sintered plates and fitted in the reactor, which was heated to constant temperature by an electric heating jacket. The reactor was equipped with a magnetic stirrer. A certain amount of the catalyst was put in the reactor, while water, oil, and the gas were separately pumped in with the high-pressure pumps. A monophasic mixture formed. The products and unreacted reactants were collected in the separator. The reaction progress was followed

*To whom correspondence should be addressed at Faculty of Chemistry and Chemical Engineering, University of Maribor, Smetanova 17, 2000 Maribor, Slovenia. E-mail: zeljko.knez@uni-mb.si

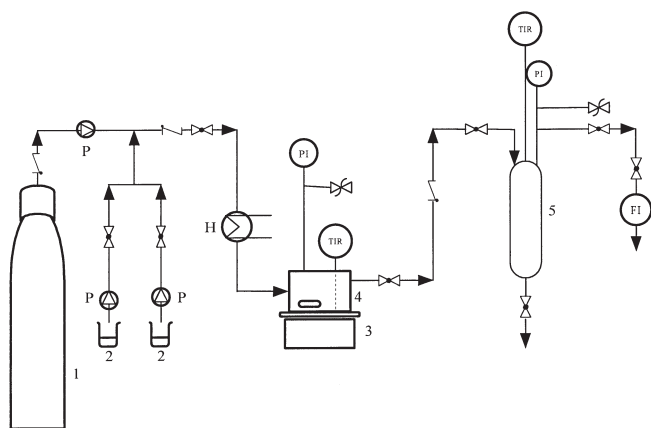

FIG. 1. High-pressure continuous flat-shaped membrane reactor; 1, CO₂; 2, substrates; 3, magnetic stirrer; 4, reactor; 5, separator; P, high-pressure pump; TIR, temperature regulator and indicator; PI, pressure indicator. The volume of the reactor was 45 mL.

by determination of FFA titrimetrically (6), and the amounts of free oleic and linoleic acids were determined by HPLC (7).

RESULTS AND DISCUSSION

Optimal parameters for the hydrolysis of sunflower oil in a high-pressure batch stirred tank reactor (3). Optimal reaction parameters, determined previously for the determination of thermodynamic parameters, included optimal lipase concentration, 0.0714 g/mL of CO₂-free reaction mixture; optimal pressure, 200 bar; optimal buffer/oil ratio, 1:1 (w/w); and optimal temperature, 50°C.

Thermodynamic parameters. Below enzyme-inactivating temperatures, enzyme-catalyzed reactions generally increase in rate with increases in temperature. This effect was observed for lipase-catalyzed hydrolysis of sunflower oil in supercritical (SC) CO₂ at 200 bar and was described with an Arrhenius relationship (8). From an Arrhenius plot (Fig. 2) it is obvious that the activity of the lipase between 35 and 50°C increased, and that with further temperature increase thermal deactivation occurred. On the basis of the slope of the straight lines in Figure 2, the calculated activation energy (E_a) was 32.7 kJ/mol. In considering transition-state theory (9), the Gibbs energy (ΔG_f), enthalpy (ΔH_f), and entropy (ΔS_f) of formation were calculated from equations

$$\Delta H_f = E_a - RT \quad [1]$$

where R is the gas constant, and T is temperature (K);

$$\Delta S_f = R \cdot \ln\left(\frac{A \cdot N_A \cdot h}{RT}\right) - R \quad [2]$$

where N_A is the Avogadro constant, A is the frequency factor, and h is Planck's constant. The Gibbs energy of formation is given by

$$\Delta G_f = \Delta H_f - T\Delta S_f \quad [3]$$

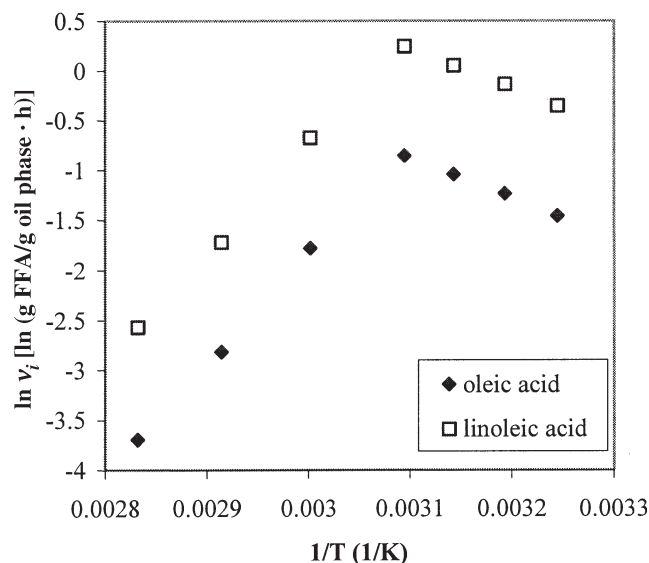

FIG. 2. Arrhenius plot for the hydrolysis of sunflower oil in supercritical CO₂ at 200 bar in the presence of Lipolase 100T. Reactions at different temperatures were performed in the high-pressure batch stirred tank reactor; v_i = initial reaction rate in g FFA/(g oil phase · h).

Enthalpy and entropy of formation or activation of the chemical reaction provide valuable information about the nature of the transition state, and hence about the reaction mechanism. Values for each magnitude are presented in Table 1. The enthalpy of formation was positive and relatively low, indicating that the reaction was slightly endothermic. The entropy of formation for hydrolysis was low and negative. The reaction was associated with a large increase in the free energy of formation, which means that the reverse reaction proceeded spontaneously.

A large enthalpy of activation indicates that a large amount of stretching, squeezing, or even breaking of chemical bonds is necessary for the formation of the transition state. The entropy of activation gives a measure of the inherent probability of the transition state, apart from energetic considerations. If ΔS_f is large and negative, the formation of the transition state requires the reacting molecules to adopt precise conformations and approach one another at a precise angle (9).

As the temperature increases, the atoms in an enzyme molecule have greater energies and a greater tendency to move. At a certain temperature they acquire sufficient energy to overcome the weak interactions holding the globular protein structure together, and deactivation follows (1). At temperatures above 50°C, deactivation of lipase was observed here. Lipolase 100T at 50°C exists in equilibrium between inactive

TABLE 1
Thermodynamic Values for Hydrolysis of Sunflower Oil with Lipolase 100T in Supercritical CO₂

	Symbols	Value
Enthalpy of formation	ΔH_f	29.7 ± 0.1 kJ/mol
Free energy of formation	ΔG_f	107 ± 0.1 kJ/mol
Entropy of formation	ΔS_f	-0.219 ± 0.002 kJ/mol·K

and active forms. At temperatures above 50°C, the deactivation enthalpy change (ΔH_d) is higher than the energy of activation. Enzyme deactivation predominates in the system and causes great activity decrease with further temperature rise. Thermal deactivation of enzymes may be reversible, irreversible, or a combination of the two. A simple model of reversible thermal deactivation often suffices to represent thermal activity relationships for enzymes over a wide range of temperatures (1). We assumed that the lipase existed in inactive and active forms in equilibrium, with equilibrium constant K_d . The slope of the Arrhenius diagram at higher temperatures is equal to $(\Delta H_d - E_d/R)$ (1). The slopes of the lines were determined using linear regression, and the deactivation enthalpies, Gibbs free energy of deactivation, and entropy of deactivation were determined with Equation 4:

$$K_d = \exp\left(\frac{-\Delta G_d}{RT}\right) = \exp\left(\frac{-\Delta H_d}{RT}\right) \cdot \exp\left(\frac{\Delta S_d}{R}\right) \quad [4]$$

where K_d represents the deactivation constant, the equilibrium constant between inactivated and activated enzyme. The deactivation constant can be written as

$$K_d(T_{\max}) = \frac{E_a + R \cdot T_{\max}}{\Delta H_d - E_a - R \cdot T_{\max}} \quad [5]$$

For a T_{\max} of 50°C, values for each parameter are presented in Table 2. The deactivation enthalpy was relatively high (123 kJ/mol) indicating that the proportion of enzyme in the active state was quite sensitive to changes in temperature.

Hydrolysis in HP CFSMR. (i) *Influence of substrate flow rate on the rate of lipolysis.* Industrial applications of enzyme-catalyzed reactions are best conducted in a continuous mode. For that purpose, a high-pressure continuous stirred membrane reactor was constructed here. A polysulfone membrane with a nominal M.W. cutoff of 10,000 was used as separation unit since it should retain the biocatalyst while allowing products as well as unreacted substrates to pass through the membrane.

Lipase-catalyzed hydrolysis of sunflower oil in SC CO₂ was performed in the HP CFSMR at 50°C and 200 bar by using Lipolase 100T as in the previous experiments. The flow rate of CO₂ was 0.8 L/h. Figure 3 shows the dependence of the amount of liberated FFA on the flow rate of the substrates and their concentration ratio. Maximum levels of released FFA were achieved within 60 min of reaction under most conditions examined and remained constant thereafter.

TABLE 2
Values for Deactivation Magnitudes of Lipase Lipolase 100T in Supercritical CO₂

	Symbols	Values
Deactivation enthalpy	ΔH_d	123 ± 0.1 kJ/mol
Deactivation constant	K_d	0.405 ± 0.002
Free energy of deactivation	ΔG_d	2.65 ± 0.01 kJ/mol
Entropy of deactivation	ΔS_d	0.339 ± 0.002 kJ/mol·K

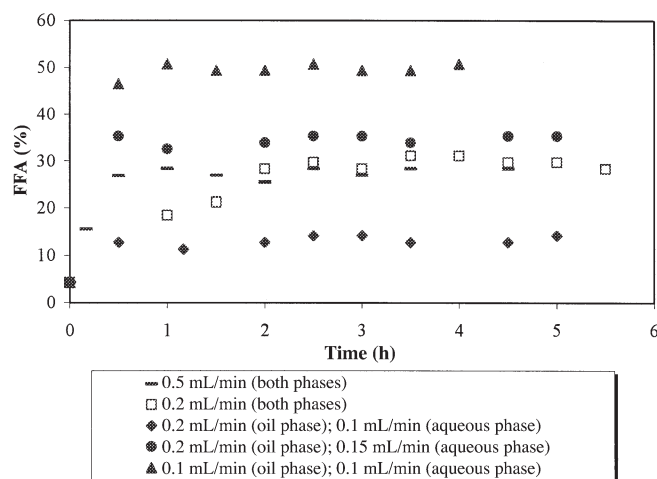

FIG. 3. Dependence of FFA release on substrate flow rates and ratios in the Lipolase 100T-catalyzed hydrolysis of sunflower oil in supercritical CO₂ in a high-pressure continuous flat-shaped membrane reactor (HP CFSMR). Reaction conditions: T = 50°C, p = 200 bar; lipase concentration = 16.67 g of lipase/L reactor volume. FFA (%) = amount of FFA, as a percentage, in the product.

The flow rate of substrates must be low enough to allow them to solubilize in SC CO₂ and react in that medium. This may explain why a flow rate for substrates of 0.1 mL/min resulted in a higher extent of lipolysis than higher flow rates. A greater degree of hydrolysis of sunflower oil by Lipolase 100T was achieved using a high-pressure batch stirred tank reactor, but not until after 48 h of operation (3). With the HP CFSMR, steady-state lipolysis was generally achieved within 1 h and subsequently maintained.

Influence of pressure and temperature on the conversion. Experiments at different temperature and pressure combinations in SC CO₂ have shown that the greatest activity of Lipolase 100T is at 50°C and 200 bar (Fig. 4), which are the same

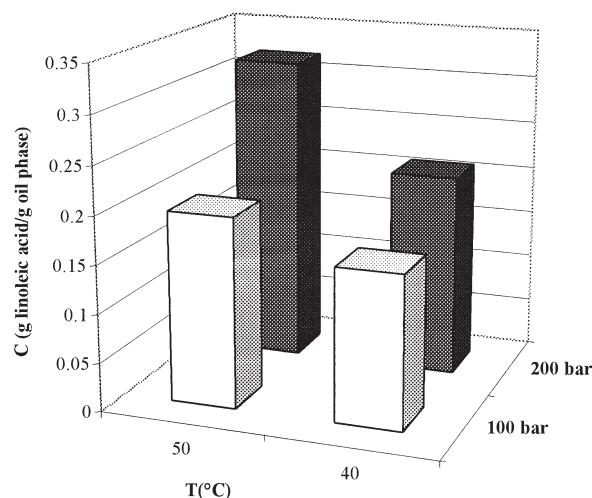

FIG. 4. Concentration of linoleic acid after 5 h as a function of temperature and pressure in an HP CFSMR. Reaction conditions: flow rate of oil and buffer = 0.1 mL/min (each), flow rate of CO₂ = 0.8 L/h, lipase concentration = 16.67 g lipase/L reactor volume. See Figure 3 for abbreviation.

results as obtained for the reaction performed in the HP BSTR. Figure 4 shows the concentration of linoleic acid after 5 h as a function of temperature and pressure. Similar results were obtained for oleic acid and are not shown, because the trends for release of both fatty acyl groups were identical, i.e., both FA are good substrates for lipase.

To obtain higher conversion in HP CFSMR, some other reactor parameters need to be optimized, such as lipase concentration, gas flow rate, and the like.

ACKNOWLEDGMENT

This work was supported in part by research grants from the Slovenian Ministry of Education, Science and Sport.

REFERENCES

1. Bailey, J.E., and D.F. Ollis, *Biochemical Engineering Fundamentals*, 2nd edn., McGraw-Hill, New York, 1986.
2. Wiseman, A., *Handbook of Enzyme Biotechnology*, 2nd edn., John Wiley & Sons., New York, 1985, pp. 54–146.
3. Primožič, M., M. Habulin, and Ž. Knez, Parameter Optimization of Enzymatic Hydrolysis of Sunflower Oil in High-Pressure Reactors, *J. Am. Oil Chem. Soc.* 80:643–646 (2003).
4. Habulin, M., and Ž. Knez, Influence of Reaction Parameters on Synthesis of *n*-Butyl Oleate by Immobilized *Mucor miehei* Lipase, *Fat Sci. Technol.* 95:249–252 (1993).
5. Hyde, J.R., P. Licence, D. Carter, and M. Poliakoff, Continuous Catalytic Reactions in Supercritical Fluids, *Appl. Catal. A* 222:119–131 (2001).
6. Leitgeb, M., and Ž. Knez, The Influence of Water on the Synthesis of *n*-Butyl Oleate by Immobilized *Mucor miehei* Lipase, *J. Am. Oil Chem. Soc.* 67:775–778 (1990).
7. Knez, Ž., and M. Habulin, Lipase-Catalyzed Esterification at High Pressure, *Biocatalysis* 9:115–121 (1994).
8. Cornish-Bowden, A., *Fundamentals of Enzyme Kinetics*, Portland Press, London, 1995.
9. Knez, Ž., M. Habulin, and V. Krmelj, Enzyme Catalyzed Reactions in Dense Gases, *J. Supercrit. Fluids* 14:17–29 (1998).

[Received May 30, 2002; accepted March 7, 2003]